

Cam-Tech Products, Inc.

General Catalog

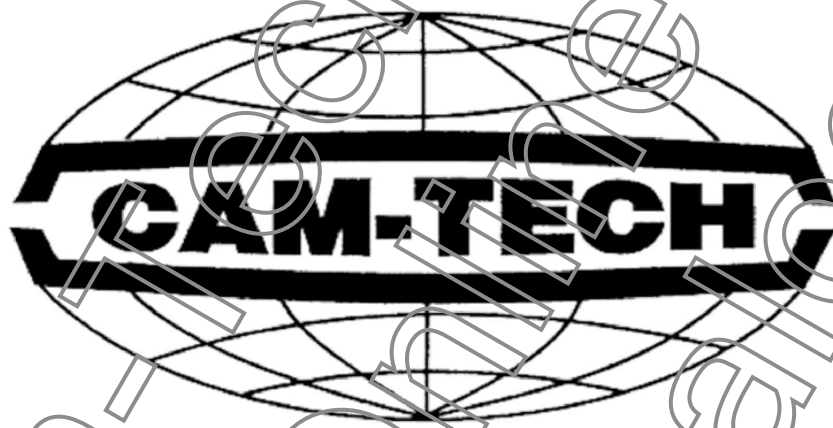

Mail to: P.O. Box 1177
Humble, TX 77347-1177

Ship to: 1811 Humble Place Drive
Humble, TX 77338

Phone: 281-548-2400

Fax: 281-548-2401

E-mail: sales@cam-tech.com

Website: www.cam-tech.com



7K-0032

Cam-Tech Products is dedicated to providing the drilling industry quality pipe handling equipment, excellent service, and competitive prices. Our sales representatives and agent network are qualified and respected with many years of experience and are capable of handling the most complex situations.

CAM-TECH current products include ...

- **Kelly Bushings — Pin and Square Drive**
 - **Kelly Bushing Safety Drive Pin**
 - **Master Bushings — Solid, Hinged, and Split**
 - **Casing Bowls — through 30"**
 - **Rotary Slips — Short, Medium, and Long**
 - **Safety "Flex" Handles for Manual Slips**
 - **Drill Collar Slips — Short, Regular, and Long**
 - **Casing Slips — through 30"**
 - **Safety Clamps — through 30"**
 - **Air Slip (AS-16) -- Hydraulic Slip (HS-16)**
 - **SSW-10 Spinning Wrenches and parts**
 - **SSW-30 Spinning Wrenches and parts**
 - **SSW-40 Spinning Wrenches and parts**
 - **Hydraulic Power Supply**
-

CAM-TECH reconditioned equipment include ...

- **Kelly Bushings**
- **Master Bushings and Bowls**
- **Rotary Slips**
- **Drill Collar Slips**
- **Spinning Wrenches**
- **Kelly Spinners**
- **TW-61 Torque Wrenches**
- **Iron Roughnecks**
- **Spring Slips (PS-15)**
- **Power Slips (PS-16)**

Cam-Tech Products, Inc.

Product Index

<u>Product Description</u>	<u>Page Number</u>
AS-16 Air Slip (HS-16 Hydraulic Slip)	1
Spinning Wrenches	2-4
Hydraulic Power Supply	5
Kelly Bushings	6-10
Master Bushings	11-15
Casing/Bowls	16
Rotary Slips	17-19
Safety "Flex" Handles	18
Drill Collar Slips	20
Casing Slips	21-22
Safety Clamps	23

AS-16 Air Slip

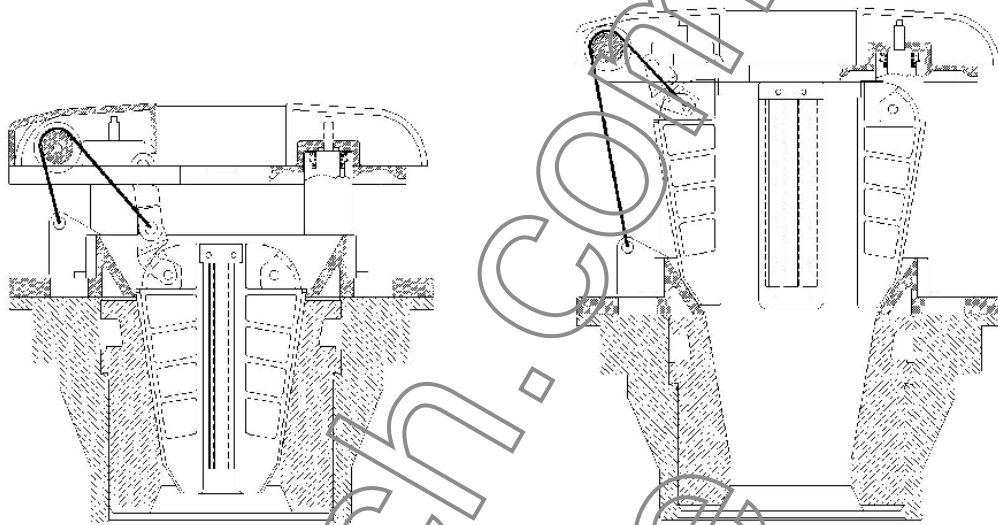

- The AS-16 Air Slip is designed to fit 27-1/2", 37-1/2", and 49-1/2" Pin Drive Master Bushings
- The AS-16 will accommodate 3-1/2" through 6-5/8" O.D. Drill Pipe
- Fits directly over the Master Bushing and does not hinder rig personnel movement
- 7" opening for easy access or removal
- The slips are set by gravity and released by air pressure

Air Slip AS-16	Slip Body Size	Drill Pipe Size	Insert Set	Insert Spacer (12 req'd)	Slip Segments Only
C-AS16-4535	4-1/2	3-1/2	2163-54	n/a	C-90700-PS
C-AS16-4540	4-1/2	4	2164-54	n/a	C-90710-PS
C-AS16-4545	4-1/2	4-1/2	2165-54	n/a	C-90720-PS
C-AS16-5545	5-1/2	4-1/2	2168-54	n/a	C-90730-PS
C-AS16-5550	5-1/2	5	2169-54	n/a	C-90740-PS
C-AS16-5555	5-1/2	5-1/2	2170-54	n/a	C-90750-PS
C-AS16-7578	7	5-7/8	2656-60	201349-5	Special Order
C-AS16-7658	7	6-5/8	2172-60	201349-5	Special Order

SSW-10 Spinning Wrench

P/N C-10426 ... Pneumatic Safety Spinning Wrench, Model SSW-10
 Cam-Tech Safety Spinning Wrench Model SSW-10, right and left hand rotation for 3-1/2" to 5-1/2" OD Drill Pipe. Includes filter, lubricator, and regulator assemblies, and 25' x 1-1/4" air hose with fittings.

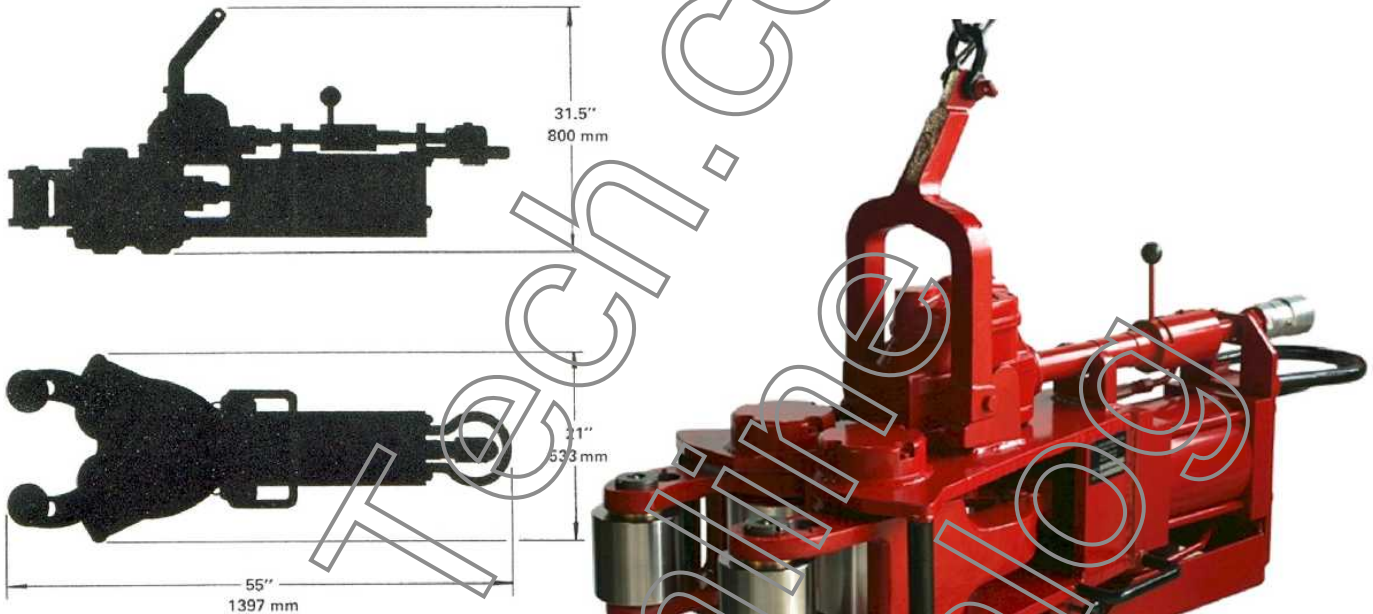

NOTE: Safety Handles included on all Cam-Tech spinning wrenches.

Drill Pipe OD (inches)	Part Number * Pressure Roller Assy. ONLY	Part Number SSW-10 w/Pressure Rollers
3-1/2	12035	C-10426-35
4	12040	C-10426-40
4-1/2	12045	C-10426-45
5	12050	C-10426-50
5-1/2	12055	C-10426-55

Specifications:

Range 3-1/2" to 5-1/2" (89 mm—140 mm)
 Air Pressure: Minimum 90 psi (6.33 kg—cm²)
 Air Pressure: Maximum 125 psi (8.75 kg—cm²)
 Air Consumption 240 cfm
 RPM 80—100 (on 5" drill pipe)
 Stall Torque 1,000 ft. pounds (on 5" drill pipe)
 Weight 810 pounds (370 kg)

SSW-30 Spinning Wrench

P/N C-19000 ... Hydraulic Safety Spinning Wrench, Model SSW-30

Cam-Tech Safety Spinning Wrench Model SSW-30 hydraulic powered with vertical positioning system, right and left hand rotation, complete self-adjusting for 2-7/8" OD to 9-1/2" OD Drill Pipe and Drill Collars

PART NUMBER: C-19000-6 (Closed Center)

PART NUMBER: C-19000-7 (Open Center)

Hydraulic Pressure Hose Assembly

3/4" diameter rated at 3,000 psi maximum operating pressure

Part Number	Length (feet)
58314-6	6
58314-15	15
58314-25	25
58314-35	35
58314-50	50

Hydraulic Return Hose Assembly

1" diameter rated at 2,000 psi maximum operating pressure

Part Number	Length (feet)
58518-6	6
58518-15	15
58518-25	25
58518-35	35
58518-50	50

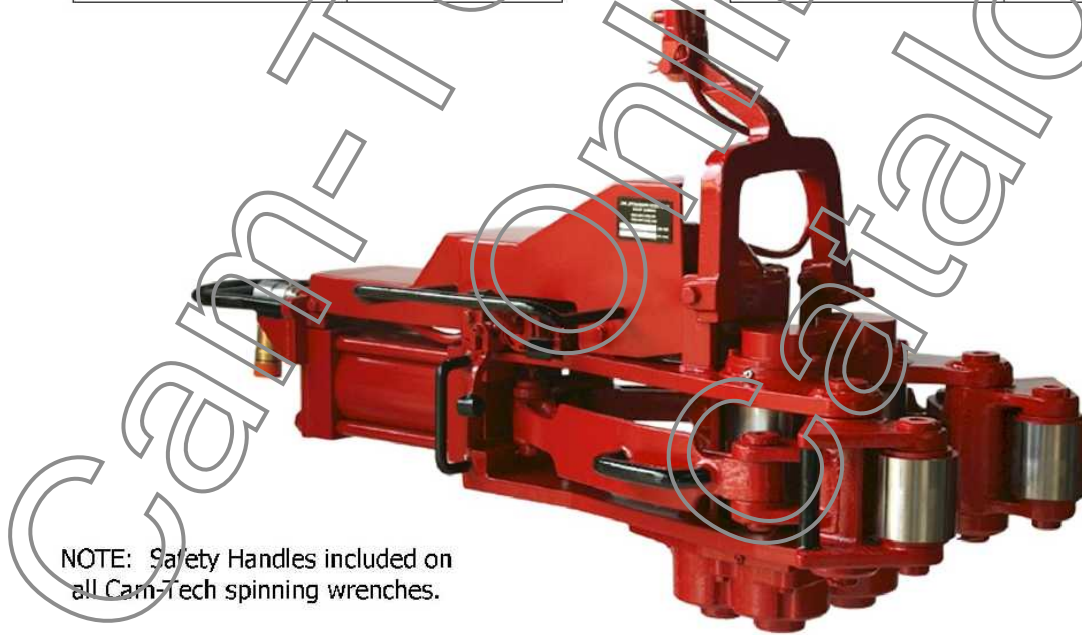

NOTE: Safety Handles included on all Cam-Tech spinning wrenches.

Specifications:

- Size Range 2-7/8" to 9-1/2" OD Drill Pipe/Drill Collar
- Normal Operating Pressure 2,000 PSI
- Torque (5" dia. Pipe) 900—1,000 ft.—lbs.
- Speed (5' dia. Pipe) 100 rpm
- Weight 850 pounds
- Hydraulic Power Requirement 29—45 GPM

SSW-40 Spinning Wrench

P/N C-73109 ... Pneumatic Safety Spinning Wrench, Model SSW-40

Cam-Tech Pneumatic Safety Spinning Wrench Model SSW-40, with vertical positioning system, right and left hand rotation, self-adjusting for 3-1/2" OD to 9-1/2" OD Drill Pipe and Drill Collars. Includes filter, lubricator, and regulator assemblies, and 25' x 1-1/4" air hose with fittings.

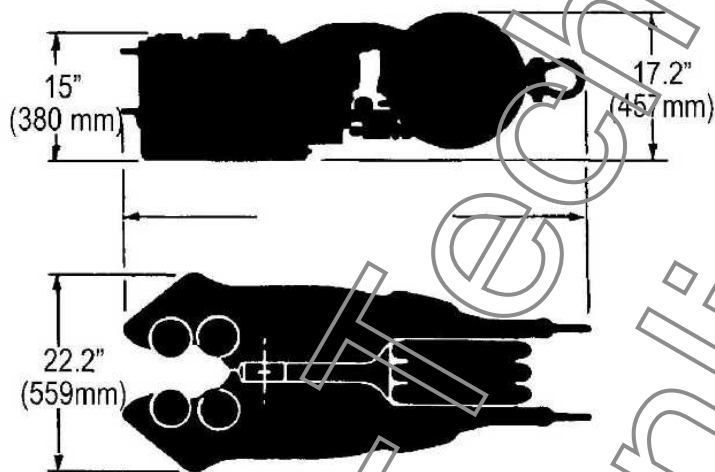

NOTE: Safety Handles included on all Cam-Tech spinning wrenches.

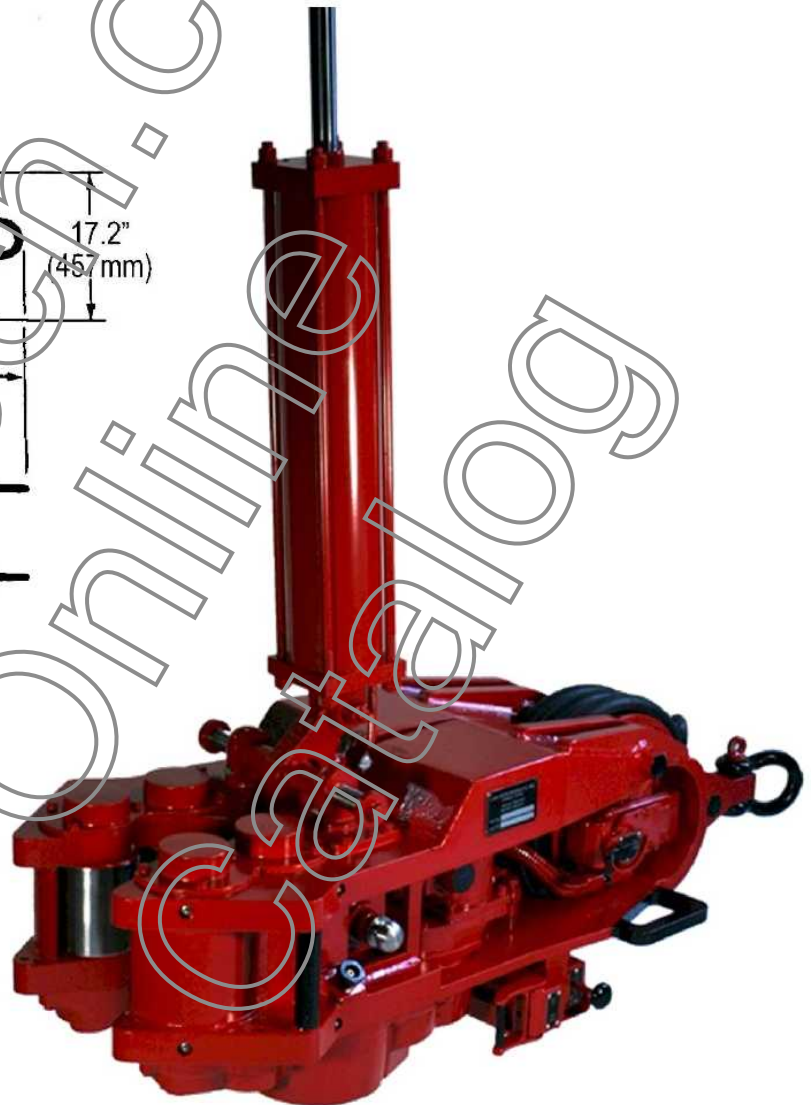

Specifications:

Range	3-1/2" to 9-1/2" Drill Pipe/Drill Collar
Air Pressure	Min. 90 psi, Max. 160 psi
Air Consumption	Max. 250 CFM
RPM	0-125 (5" OD Pipe)
Stall Torque	1,200 ft.—lbs.
Weight	1,200 lbs.

Hydraulic Power Supply

Cam-Tech "HPU" Hydraulic Power Units

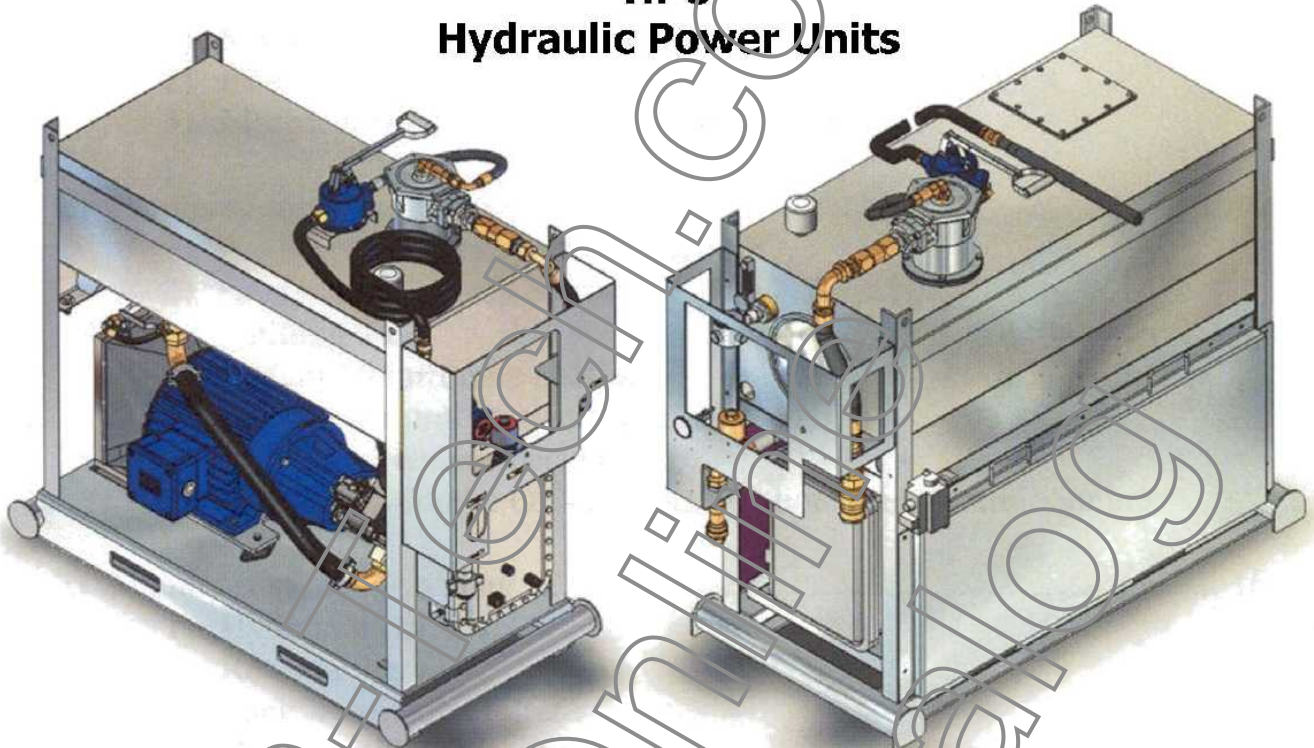

P/N 84032-460

- One 37-gpm (max.), Kawasaki Axial Piston Pump (80 cc/rev.) with horsepower compensation controls. Output pressure to be 3,000 psig maximum (specify). Also available in dual units.
- Reservoir holds 100 gallons of hydraulic oil, and constructed of 10-gauge stainless steel. Reservoir includes sight gauge, an access cover, baffle, fill port, and breather.
- Motor/pump mounted on isolation mounts to minimize sound levels.
- Explosion-proof motors and explosion-proof start/stop station with 100 foot cord.

Roller Kelly Bushing

HDP *



Heavy Duty fits 23" through 49-1/2" Rotary Tables

HDS



Heavy Duty for Square Drive Rotary Tables

MDS



Medium Duty for Square Drive Rotary Tables

* All Cam-Tech Pin Drive Kelly Bushings are sold with Cam-Tech Safety Drive Pins (C-1605-SP)

ROLLER KELLY BUSHINGS, COMPLETE

<i>Kelly size</i>	<i>HDP * part no.</i>	<i>HDS part no.</i>	<i>MDS part no.</i>
3" HEX	C-3650-30	C-3635-30	C-70484-H30
3-1/2" HEX	C-3650-35	C-3635-35	C-70484-H35
4-1/4" HEX	C-3650-42	C-3635-42	C-70484-H42
5" HEX	C-3650-50	C-3635-50	...
5-1/4" HEX	C-3650-52	C-3635-52	...
6" HEX	C-3650-60	C-3635-60	...
2-1/2" SQUARE	C-70484-S25
3" SQUARE	C-3651-30	C-3636-30	C-70484-S30
3-1/2" SQUARE	C-3651-35	C-3636-35	C-70484-S35
4-1/4" SQUARE	C-3651-42	C-3636-42	C-70484-S42
5-1/4" SQUARE	C-3651-52	C-3636-52	...
6" SQUARE	C-3651-60	C-3636-60	...
LESS ROLLERS	C-3653	C-3637	C-70483

Replacement Parts, Roller Kelly Bushing

NEW

Patent Pending

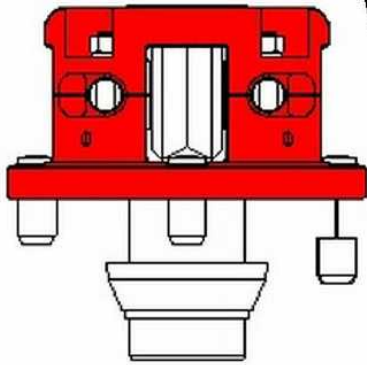

Broken Drive Pin

SAFETY DRIVE PIN P/N C-1605-SP "ADVANTAGES"

- Standard installation, operation of industry standard drive pins
- Eliminates the need for inspection or maintenance of drive pins
- Safety Drive Pins can be provided for all size drive pins
- Ease of identifying Safety Drive Pins vs. standard drive pins
- Stainless Steel Components, non-corrosive
- Visual Indication of Pin Failure
- Eliminates the potential of personnel injury or death caused by falling drive pin segment

Included on all new Cam-Tech pin drive Kelly Bushings

HDP & HDS

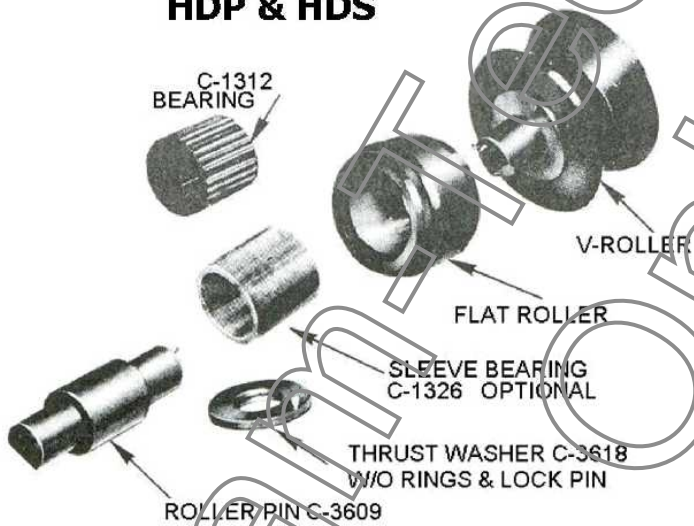

MDF & MDS

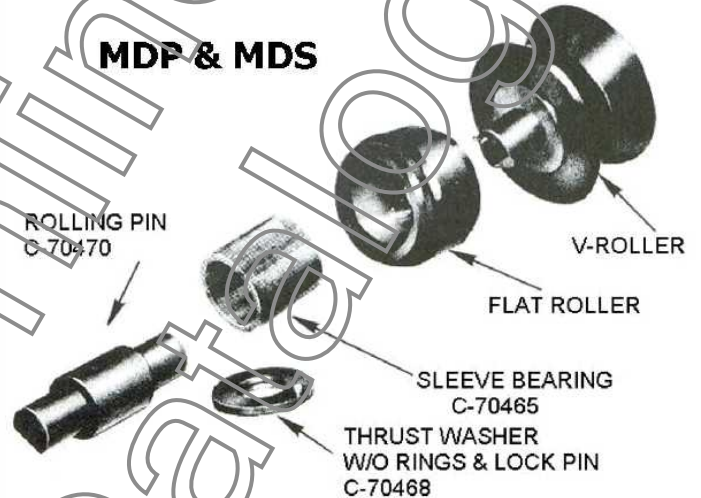

4KRVS

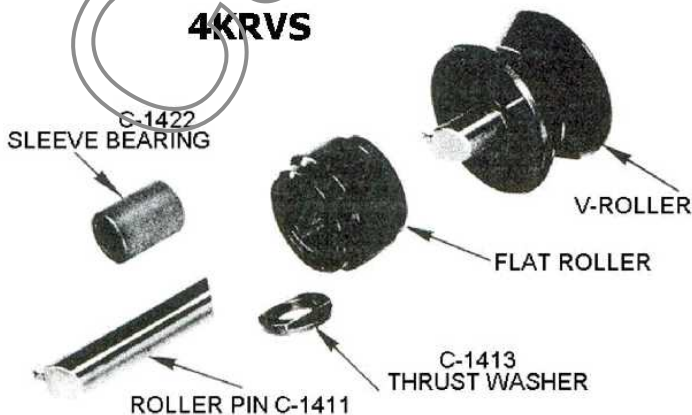

4KRBM



Roller Kelly Bushing

ROLLER ASSEMBLIES, COMPLETE

Kelly Size/Type (inches)	HDP	HDS	XHDP	MDP	MDS	4KRVS	4KRBM
3 HEX	C-3667	C-3667	...	C-70471-1	C-70474-1	C-1450	C-5210
3-1/2 HEX	C-3668	C-3668	...	C-70474-2	C-70474-2	C-1451	C-5211
4-1/4 HEX	C-3669	C-3669	...	C-70474-3	C-70474-3	C-1452	C-2948
5 HEX	C-3671	C-3671
5-1/4 HEX	C-3672	C-3672
6 HEX	C-3673	C-3673
2-1/2 SQUARE	C-70474-4	C-70474-5	C-1445	C-2949
3 SQUARE	C-3660	C-3660	...	C-70474-5	C-70474-5	C-1446	C-2943
3-1/2 SQUARE	C-3661	C-3661	...	C-70474-6	C-70474-6	C-1447	C-2944
4-1/4 SQUARE	C-3662	C-3662	...	C-70474-7	C-70474-7	C-1448	C-2945
5-1/4 SQUARE	C-3665	C-3665	C-1464	...
6 SQUARE	C-3666	C-3666

ROLLERS ONLY (4 per set)

Kelly Size/Type (inches)	HDP & HDS ‡		MDP & MDS		4 KRVS		4KRBM	
	Part No.	Wt. lb.	Part No.	Wt. lb.	Part No.	Wt. lb.	Part No.	Wt. lb.
2-1/2 SQUARE	C-70493-4	129	C-1430-4	186	C-2933-4	84
3 SQUARE	C-1331-4	396	C-70593-5	113	C-1431-4	168	C-2930-4	70
3-1/2 SQUARE	C-1332-4	368	C-70593-6	97	C-1432-4	144	C-2931-4	56
4-1/4 SQUARE	C-1333-4	318	C-70593-7	69	C-1433-4	116	C-2932-4	34
5-1/4 SQUARE	C-1334-4	244	C-1434-4	72
6 SQUARE	C-1335-4	180
3 HEX	C-1338-39	418	C-70593-1	99	C-1437-38	174	C-5221-22	76
3-1/2 HEX	C-1340-41	390	C-70593-2	88	C-1439-40	160	C-5223-24	62
4-1/4 HEX	C-1342-43	338	C-70593-3	63	C-1441-42	134	C-2939-40	42
4-1/2 HEX	C-1385-86	302
5 HEX	C-1387-88	292
5-1/4 HEX	C-1344-45	292
6 HEX	C-1346-47	220

‡ Rollers for Cam-Tech HDP, HDS, 4KRP and 4KRS Kelly Bushings are interchangeable.

Roller Kelly Bushing

ROLLER KELLY BUSHING PARTS

Description	HDP & HDS		MDP & MDS		4KRVS		4KRBM		4KRP/KRS	
	P/N	Wt. lb.	P/N	Wt. lb.	P/N	Wt. lb.	P/N	Wt. lb.	P/N	Wt. lb.
Roller Pin	C-3609	33	C-70470	8.5	C-1411	8	C-2910	5	C-1311	26
Sleeve Bearing	C-1326	2	C-70465	1	C-1422	8	C-5218	.25	C-1326	2
Roller Bearing	C-1312	7	C-1412	3	C-1312	7
Thrustwasher with O'Rings	C-3618	5	C-70468	1.75	C-1413	3	C-2192	.5	C-1313	3
I.D., O'Ring	C-51300-233-B	.10
O.D., O'Ring	C-51300-255-B	.10
Nut	C-1208	1.75	C-1208	1.75	C-1208	1.75	C-1208	1.75	C-1208	1.75
Lockwasher	C-50924	.25	C-50924	.25	C-50924	.25	C-50924	.25	C-50924	.25
Wrench	C-1210	8	C-1210	8	C-1210	8	C-1210	8	C-1210	8
Safety Drive Pin	C-1605-SP ‡	10	C-1505-SP	9	C-1605-SP ‡	10
Drive Pin Washer	C-1506	1	C-1506	1	C-1506	1
Holddown Bolt/Stud	C-13501	7	C-70458	5.5	C-1414	5	C-5230	5	C-1315	5.5
Holddown Bolt Ret.	C-50110-8-S	25	C-72366	25
Lockwasher	C-51110-C
Locking Pin	C-1316	...

‡ C-1505-SP on 20-inch models.

KELLY BUSHING SAFETY GUARD

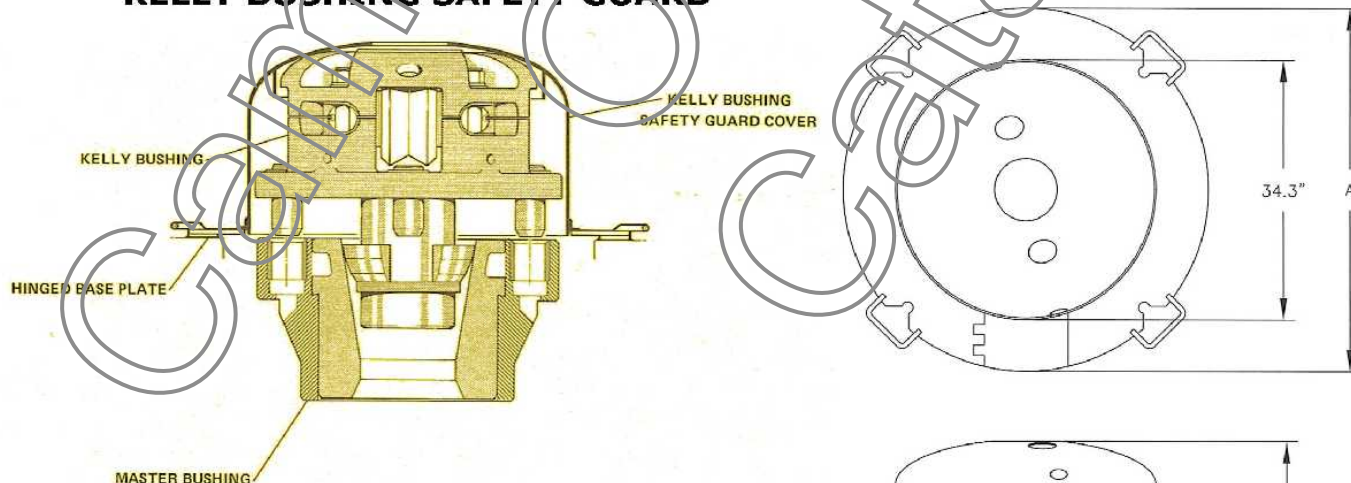

SPECIFICATIONS AND ORDERING INFORMATION	Part No.	Wt. lbs.	Dimension "A"
For 22-27-1/2 Rotary Table	C-15744-6	347	48
For 37-1/2 Rotary Table	C-16951-6	519	62
For 49-1/2 Rotary Table	C-16953-6	717	75

Kelly Bushing Lock Assembly

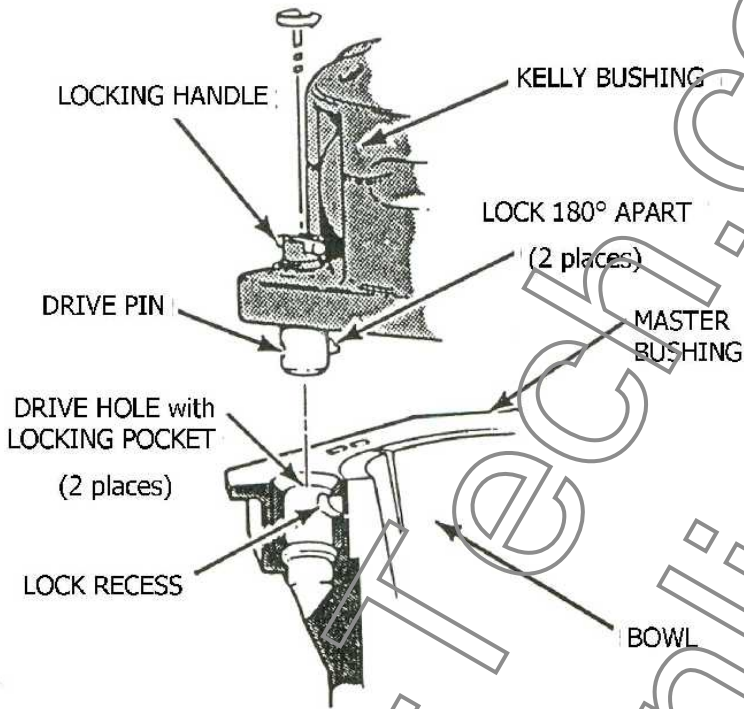

Index No.	Part No.	Name	Qty.
—	C-3695	LOCK ASSY.	2
1	C-1506	WASHER, Drive Pin	1
2	C-51205-11	PIN, Lock	1
3	C-3697	PIN, Locking Drive	1
4	C-3696	PIN, Eccentric	1
5	C-3698	PIN, HDP lock	1

Optional Lock Assembly locks the Kelly Bushing in the Master Bushing for use offshore with motion compensators.

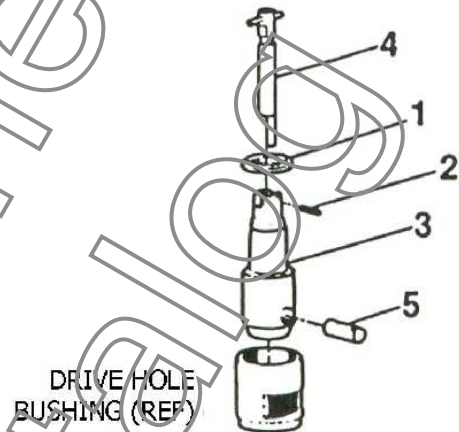

Screw (HDP, HDS) C-50008-10-S
(4KRVS, 4KRBM) C-50106-8-SD
(MD) C-50006-10-C5

Wiper (HDP, HDS) 10 in. OD
(4KRVS, 4KRBM, MD) 8-1/8 in. OD



Retaining Plate (HDP, HDS) C-1321
Retaining Ring (4KRVS, 4KRBM) C-1417
Retaining Plate (MD) C-70491



Wipers for hexagonal Kellys

KELLY WIPERS

	Kelly Size (inches)	Square Part No.	Hex Part No.
HDP and HDS Kelly Bushings	3 API	8-0260	8-0320
	3-1/2 API	8-0265	8-0285
	4-1/4 API	8-0170	8-0275
	5-1/4 API	8-0300	8-0305
	6 API	8-0200	8-0240
MDP and MDS Kelly Bushings	2-1/2 API	8-0245	...
	3 API	8-0165	8-0235
	3-1/2 API	8-0325	8-0230
	4-1/4 API	8-0345	8-0290

Master Bushing

MSPC



Fits 20-1/2" and 27-1/2"
Rotary Tables

MSS

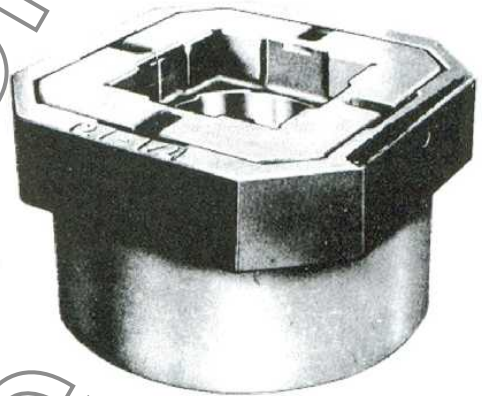

Fits 17-1/2" and 27-1/2"
Rotary Tables

MPCH



Fits 37-1/2" and 49-1/2"
Rotary Tables

**MSP and MDSP
"Split"**



Fits 17-1/2" - 27-1/2"
Rotary Tables

**MBSS
"Split"**

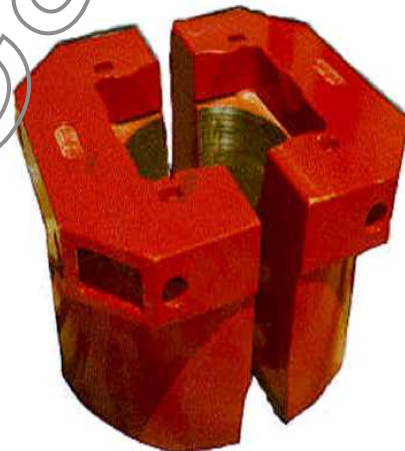

Fits 17-1/2" - 27-1/2"
Rotary Tables

Master Bushing

INSERT BOWLS



Bowl No. 1

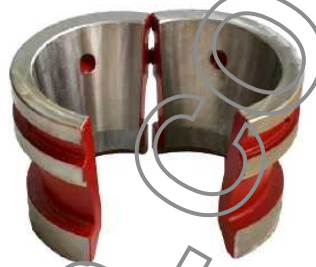

Bowl No. 2



Bowl No. 3

MPCH PARTS LIST

Description	Part No.	Wt. lbs.
Hinge Pin, removable	C-6604	80
Hinge Pin, stationary	C-6605	75
Hinge Pin Retainer	C-6606	1/8
Eccentric Pin	C-1014	2
Eccentric Pin Retainer	C-50106-22	1/8
Lock	C-1016	3
Drive Hole Bushing	C-3699	7
Lifting Sling	C-6699	150
Bit Breaker Plate	C-1816	220
Insert Bowl No. 1 — 13-3/8" and 11-3/4"	C-6610	336
Insert Bowl No. 2 — 10-3/4" and 9-5/8"	C-6609	470
Insert Bowl No. 3 — API 8-5/8" and smaller	C-6608	625

MSPC PARTS LIST

For Rotary Table Size (in.)	20-1/2 and 21		23		27-1/2	
	Part No.	Wt. lbs.	Part No.	Wt. lbs.	Part No.	Wt. lbs.
Description	Part No.	Wt. lbs.	Part No.	Wt. lbs.	Part No.	Wt. lbs.
Eccentric Pin	C-1013	1	C-1014	2	C-1014	2
Lock	C-1811	1.50	C-1016	3	C-1016	3
Lock Retaining Pin	C-1028	.25	C-1018	.25	C-1030	.50
Drive Hole Bushings	C-1813	3.50	C-1814	7	C-1814	7
Lifting Sling	C-1021	40	C-1021	40	C-1021	40
Bit Breaker Plate	C-1815	137	C-1816	220	C-1816	220
Insert Bowl No. 1 — 13-3/8" and 11-3/4"	C-1903	326	C-1903	326
Insert Bowl No. 2 — 10-3/4" and 9-5/8"	C-1902	242	C-1904	460	C-1904	460
Insert Bowl No. 3 — API 8-5/8" and smaller	C-1809	464	C-1810	620	C-1810	620

Master Bushing

MSS PARTS LIST

Rotary Table Size (in.)	17-1/2		20-1/2 and 21		22 and 23		27-1/2 ‡	
Description	Part No.	Wt. lbs.	Part No.	Wt. lbs.	Part No.	Wt. lbs.	Part No.	Wt. lbs.
Eccentric Pin	C-1013	1	C-1014	1	C-1014	2
Lock	C-1015	1	C-1016	3	C-1016	3
Lock Retaining Pin	C-1017	.33	C-1018	.33	C-1029	.33
Lifting Sling	C-1021	40	C-1021	40	C-1021	40	C-1021	40
Insert Bowl No. 2 10-3/4" and 9-5/8"
Insert Bowl No. 3 ** Extended API for 8-5/8" and smaller	C-1024	275	C-1024	275	C-1024	275	C-1025	980
Insert Bowl No. 3 Regular API for 8-5/8" and smaller	C-1011	226	C-1011	226	C-1011	226	C-1022	920

‡ No Bowl Lock is used in this bushing.

** Special API extended insert bowl for tripping only.

MASTER CASING BUSHING ACCESSORIES

C-1816 Bit Breaker Adapter Plate

Located in the Master Bushing drive pin holes and provides a 13-9/16 inch square to accommodate Bit Breakers with Pin Drive Master Bushings, MPCH, MSPC, and MDSP

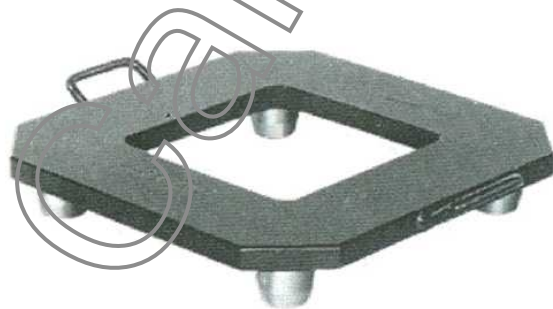

Rated Lifting Slings

For removing and installing bushings and bowls.

C-1021, with 2-hooks

C-6699, with 4-hooks



Master Bushing

Make	Size	MPCH			MSPC			MSP/MDSP			MSS			MBSS
		Comp	Body Only		Comp	Body Only		Comp	Body Only		Comp	Body Only		
API Standard	17-1/2	C-70527-1	C-70526-1	C-1001-1	C-1006-1	C-S1006-1		
	20-1/2	C-1801-1	C-1805-1	...	C-70540-1	C-70539-1	C-1002-1	C-1007-1	C-S1007-1		
	27-1/2	C-1804-1	C-1808-1	...	C-5429-1	...	C-1005-1	C-1010-1	C-S1010-1		
Bethlehem	17-1/2	C-70527-2	C-70526-2	C-1001-6	C-1006-6	...		
	B-175	C-70527-3	C-70526-3	C-1001-6	C-1006-6	C-S1006-6		
	B-210 5" Flange	C-70540-2	C-70539-2	C-1002-2	C-1007-2	...		
	B-210 5-1/2" Flange	C-70540-3	C-70539-3	C-1002-2	C-1007-2	...		
	26	C-1803-1	C-1807-1	...	C-5429-6	...	C-1004-1	C-1009-1	C-S1009-1		
B-275	C-1804-6	C-1808-6	C-1005-6	C-1010-6	C-S1010-6			
Brewster *	OB-18, RSH-18	C-70527-4	C-70526-4	C-1001-8	C-1006-8	C-S1006-8		
	RSH-22	C-15588	C-15588-1	C-1003-3	C-1008-3	C-S1008-2		
	RSH-27-1/2	C-1804-8	C-1808-8	...	C-5429-8	...	C-1005-9	C-1010-9	C-S1010-9		
Continental Emsco	L-17	C-70527-5	C-70526-5	C-1001-9	C-1006-9	...		
	T-1750	C-70527-1	C-70526-1	C-1001-1	C-1006-1	C-S1006-1		
	O-17-1/2, P-17-1/2	C-70527-6	C-70526-6	C-1001-4	C-1006-4	...		
	T-2050, O-20-1/2 P, PJ, J	C-1801-1	C-1805-1	...	C-70540-4	C-70539-4	C-1002-1	C-1007-1	C-S1007-1		
	JA, JC, JAC, JACS, JAS, JCS, JS	C-1801-3	C-1805-3	...	C-70540-5	C-70539-5	C-1002-3	C-1007-3	...		
	JAB-20-1/2, JABS, JB, JBS	C-70540-6	C-70539-6	C-1002-5	C-1007-5	...		
	D-25-1/2, DA	C-1803-4	C-1807-4		
	T-2750	C-1804-1	C-1808-1	...	C-5429-1	...	C-1005-1	C-1010-1	C-S1010-1		
	G-27-1/2	C-1804-5	C-1808-5	...	C-5429-5	...	C-1005-5	C-1010-5	...		
	H-27-1/2	C-1804-2	C-1808-2	...	C-5429-2	...	C-1005-2	C-1010-2	...		
	K-27-1/2, KS, PJ	C-1804-3	C-1808-3	...	C-5429-3	...	C-1005-3	C-1010-3	...		
	T-3750 (S/N 1-48)		
	T-3750/T-4950 (49/UP)	C-6600-2A	C-6601-2A		
Gardner-Denver	RT-17-1/2	C-70527-1	C-70526-1	C-1001-1	C-1006-1	C-S1006-1		
	RT-22-1/2	C-19334	C-19334	C-1003-2	C-1008-2	C-S1008-2		
	RT-27-1/2	C-1804-1	C-1808-1	...	C-5429-1	...	C-1005-1	C-1010-1	C-S1010-1		
	RT-37-1/2		
Hacker Pyramid	17-1/2	C-S1006-1		
	20-1/2		
	27-1/2	C-S1010-1		
	L-17-1/2	C-70527-1	C-70526-1	C-1001-1	C-1006-1	...		
Haniel & Lueg	17-1/2		
	L-17-1/2	C-70527-1	C-70526-1	C-1001-1	C-1006-1	...		

Master Bushing

Make	Size	MPCH		MSPC		MSP/MDSP		MSS		MBSS
		Comp	Body Only	Comp	Body Only	Comp	Body Only	Comp	Body Only	
Houston Systems	27-1/2	C-1804-10	C-1808-10
Idaco	17-1/4	C-70527-7	C-70526-7	C-1001-5	C-1006-5	C-S1006-5
	17-1/2, HS-175	C-70527-8	C-70526-8	C-1001-5	C-1006-5	C-S1006-5
	20-1/2	C-1801-1	C-1805-1	C-70540-1	C-70539-1	C-1002-1	C-1007-1	C-S1007-1
	23	C-1802-1	C-1806-1	C-1003-1	C-1008-1	C-S1008-1
	27-1/2	C-1804-7	C-1808-7	C-5429-7	...	C-1005-7	C-1010-7	C-S1010-7
37-1/2	C-6600-4	C-6601-4	
Mild Continent (Unit Rig)	S-17-1/2 A	C-1001-7	C-1006-7	C-S1006-7
	S-21 A	C-1002-4	C-1007-4	C-S1007-4
	S-27 1/2 A	C-1804-4	C-1804-1	C-1005-4	C-1010-4	C-S1010-4
National	A & B-175, 17-1/2
	A-205, 20-1/2	C-1801-1	C-1805-1	C-70527-9	C-70526-9	C-1001-1	C-1006-1	C-S1006-1
	MS-27-1/2, A & B-27-1/2, Q-275	C-1804-5	C-1808-5	C-70540-4	C-70539-4	C-1002-1	C-1007-1	C-S1007-1
	C-365	C-6600-5	C-6601-5	C-5429-5	...	C-1005-5	C-1010-5	C-S1010-5
	C-375	C-6600-4	C-6601-1
Ollwell	A-17-1/2
	17-1/2	C-70527-10	C-70526-9	C-1001-1	C-1006-1	C-S1006-1
	20-1/2	C-1801-3	C-1805-3	C-70527-11	C-70526-11	C-1001-3	C-1006-3	...
	A-20-1/2	C-1801-1	C-1805-1	C-70540-7	C-70539-7	C-1002-3	C-1007-3	C-S1007-1
	21 & 21A Super	C-1801-2	C-1805-2	C-70540-7	C-70539-7	C-1002-3	C-1007-3	...
	26 HD	C-1803-2	C-1807-2	C-70540-8	C-70539-8	C-1002-2	C-1007-2	...
	27-1/2, 27-1/2A	C-1804-9	C-1808-9	C-1004-2	C-1009-2	...
A-27-1/2	C-1804-1	C-1808-1	C-5429-1	...	C-1005-8	C-1010-8	...	
A-37-1/2	C-6600-3	C-6601-3	C-1005-1	C-1010-1	C-S1010-1	
Wirth	25-1/2
	27-1/2	C-1803-5	C-1807-5
	37-1/2	C-6600-3	C-6601-3	C-1804-1	C-1808-1	C-5429-1	...	C-1005-1	C-1010-1	C-S1010-1

Casing Bushing



CU Casing Bushing



CUL Casing Bushing

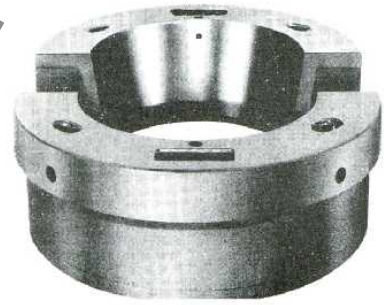

CB Casing Bushing

Rotary Table Size (inches)	Make	Casing Size (inches)	Casing Bushing & Insert Bowl (P/N)	Wt. lbs.
17-1/2—20-1/2	ALL	11-3/4 & 13-3/8 9-5/8 & 10-3/4	CU (C-3102) w/bowl #2 (C-1902)	470
26 & 27-1/2	ALL	18-5/8 & 20 16 11-3/4 & 13-3/8 9-5/8 & 10-3/4 2-3/8 & 8-5/8	CUL (C-3103) w/bowl 20x16 (C-3704) w/bowl #1 (C-3105) w/bowl #2 (C-1902) w/bowl #3 (C-1809)	938 562 846 342 464
27-1/2	ALL 27-1/2 API	18-5/8 & 20 16 11-3/4 & 13-3/8 9-5/8 & 10-3/4	CB (C-6695) w/bowl 20x16 (C-6127) w/bowl #1 (C-6126) w/bowl #2 (C-6114)	713 572 895 252
37-1/2—49-1/2	NATIONAL	30 26 24 18-5/8 & 20 16 11-3/4 & 13-3/8 9-5/8 & 10-3/4	CB (C-11763) CB (C-16454) CB (C-11253) CB (C-10187) w/bowl 20x16 (C-6127) w/bowl #1 (C-6126) w/bowl #2 (C-6114)	1100 1100 1200 1600 572 895 252
37-1/2—49-1/2	OILWELL	30 26 24 18-5/8 & 20 16 11-3/4 & 13-3/8 9-5/8 & 10-3/4	CB (C-12093) CB (C-6170-26) CB (C-6170) CB (C-10188) w/bowl 20x16 (C-6127) w/bowl #1 (C-6126) w/bowl #2 (C-6114)	1170 1100 1260 1670 572 895 252
37-1/2	CONTINENTAL EMSCO	30 26 24 22 18-5/8 & 20 16 11-3/4 & 13-3/8 9-5/8 & 10-3/4	CB (C-11653) CB (C-89183-1) CB (C-16542) CB (C-11252-22) CB (C-11553) S/N 49 & above for 37-1/2 only (C-10190) S/N 48 & below for 37-1/2 only w/bowl 20x16 (C-6127) w/bowl #1 (C-6126) w/bowl #2 (C-6114)	1160 1100 1260 1120 1610 1820 572 895 252
37-1/2	IDECO	30 24 18-5/8 & 20 16 11-3/4 & 13-3/8 9-5/8 & 10-3/4	CB (C-12092) CB (C-19178) CB (C-10189) w/bowl 20x16 (C-6127) w/bowl #1 (C-6126) w/bowl #2 (C-6114)	1100 1170 1670 572 895 252

Rotary Slip

All Cam-Tech Rotary Slips are sold with Cam-Tech Safety Flex Handles, as shown here (ref. page 18)



SDS – SHORT ROTARY SLIPS & SDS INSERTS

Slip Body Size (in.)		3-1/2			4-1/2		
Pipe Sizes (in.)		2-3/8	2-7/8	3-1/2	3-1/2	4	4-1/2
P/N: Slip w/Flex Handles & Inserts		C-3901-FH	C-3903-FH	C-3905-FH	C-3907-FH	C-3909-FH	C-3911-FH
Wt: Slip w/inserts (lbs.)		134	128	124	162	155	146
Insert Set:	P/N	2160-24	2161-24	2162-24	2163-36	2164-36	2165-36
	Wt. lbs.	21	16	10	32	25	16
	Qty.	24	24	24	36	36	36

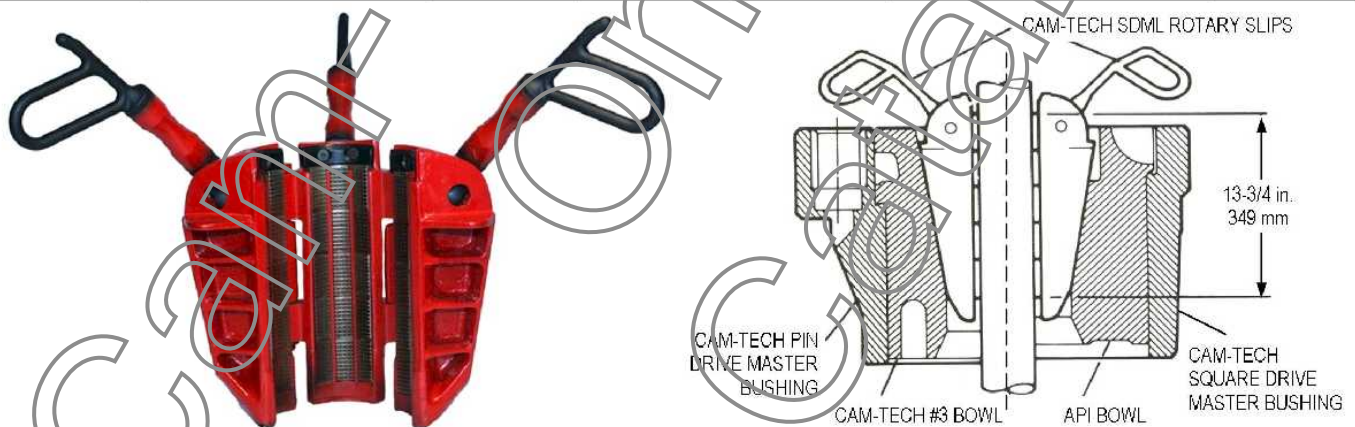

SDML – MEDIUM ROTARY SLIPS & SDML INSERTS

Slip Body Size (in.)		3-1/2			4-1/2		
Pipe Sizes (in.)		2-3/8	2-7/8	3-1/2	3-1/2	4	4-1/2
Slip w/Flex Handles & Inserts		C-15524-FH	C-15523-FH	C-15522-FH	C-15563-FH	C-15564-FH	C-15565-FH
Wt: Slip w/inserts (lbs.)		193	188	180	207	199	188
Insert Set:	P/N	2160-30	2161-30	2162-30	2163-45	2164-45	2165-45
	Wt. lbs.	26	21	13	39	31	20
	Qty.	30	30	30	45	45	45

Rotary Slip

All Cam-Tech Rotary Slips are sold with Cam-Tech Safety Flex Handles, as shown here

SDXL — EXTRA LONG ROTARY SLIPS AND INSERTS

Slip Body Size (in.)		4-1/2		
Pipe Sizes (in.)		3-1/2	4	4-1/2
P/N: Slip complete with Flex Handles & Inserts		C-15515-FH	C-15514-FH	C-15513-FH
Weight: Slip complete with Inserts	Lbs (kg)	229 (104)	219 (99)	205 (93)
Insert Set:	P/N Wt lbs (kg) Qty	2163-54 47 (21) 54	2164-54 37 (17) 54	2165-54 23 (10.5) 54



Slip Body Size (in.)		5			5-1/2		
Pipe Sizes (in.)		4	4-1/2	5	4-1/2	5	5-1/2
P/N: Slip complete with Flex Handles & Inserts		C-15518-FH	C-15517-FH	C-15516-FH	C-15521-FH	C-15520-FH	C-15519-FH
Weight: Slip complete with Inserts	Lbs (kg)	237 (107.5)	227 (103)	213 (96.5)	234 (106)	224 (101.5)	210 (95)
Insert Set:	P/N Wt lbs (kg) Qty	2168-54 47 (21) 54	2166-54 37 (17) 54	2167-54 23 (10.5) 54	2168-54 47 (21) 54	2169-54 37 (17) 54	2170-54 23 (10.5) 54



SAFETY "FLEX" HANDLE

Ordering Information

<i>Rotary Slips</i>	
Right Handle	C-3767-FH
Left Handle	C-3768-FH
Center Handle	C-3765-FH
Handle Pins	C-3769
<i>Drill Collar and Casing Slips</i>	
All Handles	C-3765-FH
Handle Pins	C-3769

CAM-TECH SDXL ROTARY SLIPS

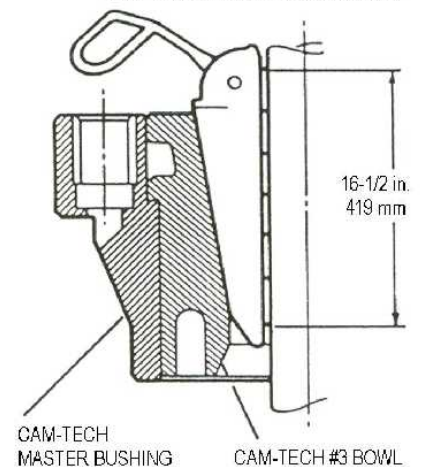

Rotary Slip

SDS — SHORT ROTARY SLIPS

Slip Body Size (in.)	3-1/2		4-1/2	
Parts List	P/N	Wt. lbs.	P/N	Wt. lbs.
Slip complete, LESS inserts	C-3906	114	C-3912	130
Slip Segment, RIGHT	C-3919	28	C-3922	37
Slip Segment, CENTER	C-3920	32	C-3923	39
Slip Segment, LEFT	C-3921	28	C-3924	37
Safety FLEX Handle, RIGHT	C-3767-FH	3.5	C-3767-FH	3.5
Safety FLEX Handle, CENTER	C-3765-FH	4	C-3765-FH	4
Safety FLEX Handle, LEFT	C-3768-FH	3.5	C-3768-FH	3.5
Handle Pin w/Washer & Cotter Pin	C-3769	.5	C-3769	.5
Hinge Pin w/Cotter Pin	C-2190	1.2	C-2190	1.2
Retaining Ring	C-3738	1.2	C-3739	1.2
Kit, Hex Nut, Bolt & Wrench	C-3737	.5	C-3737	.5
Handle, RIGHT	C-3767	3.5	C-3767	3.5
Handle, CENTER	C-3765	4	C-3765	4
Handle, LEFT	C-3768	3.5	C-3768	3.5

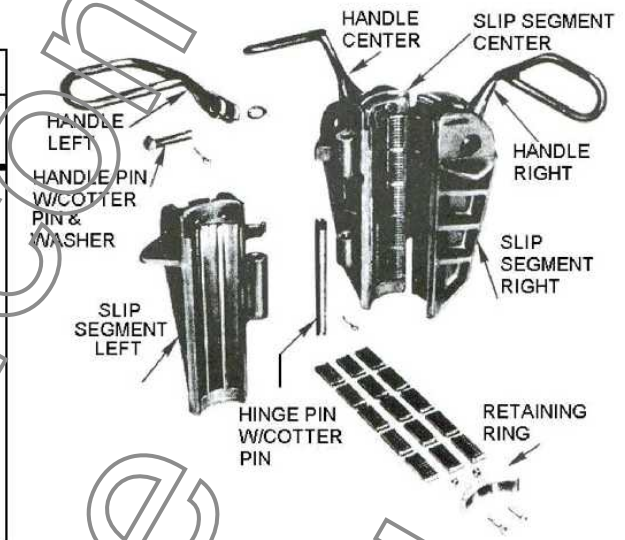

SDML — MEDIUM ROTARY SLIPS

Slip Body Size (in.)	3-1/2		4-1/2	
Parts List	P/N	Wt. lbs.	P/N	Wt. lbs.
Slip complete, LESS inserts	C-15522-1	167	C-15565-1	168
Slip Segment, RIGHT	C-15526	50	C-15529	51
Slip Segment, CENTER	C-15525	53	C-15528	54
Slip Segment, LEFT	C-15527	50	C-15530	54
Safety FLEX Handle, RIGHT	C-3767-FH	3.5	C-3767-FH	3.5
Safety FLEX Handle, CENTER	C-3765-FH	4	C-3765-FH	4
Safety FLEX Handle, LEFT	C-3768-FH	3.5	C-3768-FH	3.5
Handle Pin w/Washer & Cotter Pin	C-3769	.5	C-3769	.5
Hinge Pin w/Cotter Pin	C-2192	1.2	C-2192	1.2
Retaining Ring	C-3738	1.2	C-3739	1.2
Kit, Hex Nut, Bolt & Wrench	C-3737	.5	C-3737	.5
Handle, RIGHT	C-3767	3.5	C-3767	3.5
Handle, CENTER	C-3765	4	C-3765	4
Handle, LEFT	C-3768	3.5	C-3768	3.5

SDXL — EXTRA LONG ROTARY SLIPS

Slip Body Size (in.)	4-1/2		5	5-1/2		
Parts List	P/N	Wt. lbs.	P/N	Wt. lbs.	P/N	Wt. lbs.
Slip complete, LESS inserts	C-15562	182	C-15566	193	...	190
Slip Segment, RIGHT	C-15552	54	C-15558	53	...	56
Slip Segment, CENTER	C-15553	57	C-15559	55	...	61
Slip Segment, LEFT	C-15554	54	C-15560	53	...	56
Safety FLEX Handle, RIGHT	C-3767-FH	3.5	C-3767-FH	3.5	C-3767-FH	3.5
Safety FLEX Handle, CENTER	C-3765-FH	4	C-3765-FH	4	C-3765-FH	4
Safety FLEX Handle, LEFT	C-3768-FH	3.5	C-3768-FH	3.5	C-3768-FH	3.5
Handle Pin w/Washer & Cotter Pin	C-3769	.5	C-3769	.5	C-3769	.5
Hinge Pin w/Cotter Pin	C-2192	1.2	C-2192	1.2	C-2192	1.2
Retaining Ring	C-3739	1.2	C-3741	1.2	C-3740	1.2
Kit, Hex Nut, Bolt & Wrench	C-3737	.5	C-3737	.5	C-3737	.5
Handle, RIGHT	C-3767	3.5	C-3767	3.5	C-3767	3.5
Handle, CENTER	C-3765	4	C-3765	4	C-3765	4
Handle, LEFT	C-3768	3.5	C-3768	3.5	C-3768	3.5

Drill Collar Slip

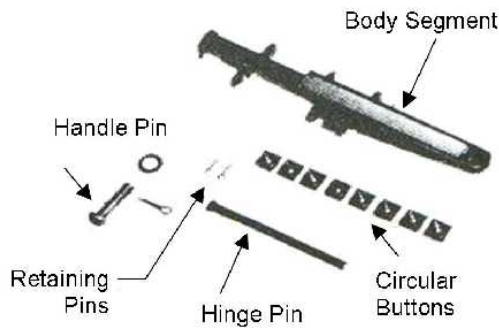

DCS-L

All Cam-Tech Drill Collar Slips are sold with Cam-Tech Safety Flex Handles, as shown here (ref. page 18)

DCS — MULTI-SEGMENT DRILL COLLAR SLIPS

Slip Type	DCS-S		DCS-R		DCS-L					
Drill Collar OD (in.)	3-4	4-4-7/8	4-1/2-6	5-1/2-7 ‡	6-3/4-8-1/4	8-9-1/2	8-1/2-10	9-1/4-11-1/4 ¥	11-12-3/4 ¥	12-14 ¥
P/N: Slip complete with Buttons and Safety FLEX Handles	C-2572-FH	C-2573-FH	C-2552-FH	C-2550-FH	C-2503-FH	C-2507-FH	C-2530-FH	C-2508-FH	C-2534-FH	C-2536-FH
Weight, complete Lbs.	112	103	129	112	154	173	185	198	213	207
Total Segments	7	7	9	9	11	12	13	14	17	17
Total Hinge Pins	6	6	8	8	10	11	12	13	16	16
Use in Insert Bowl	No. 3 Regular or Extended					No. 3 Ext.		No. 2		No. 1

‡ DCS-L P/N C-2501 also available for this size range.

¥ This size is furnished with four (4) handles.

PARTS LIST

Slip Type	DCS-S		DCS-R		DCS-L	
	P/N	Wt. lbs.	P/N	Wt. lbs.	P/N	Wt. lbs.
Segment, RIGHT End	C-2568	11	C-2554	10	C-2510	12
Segment, LEFT End	C-2569	11	C-2555	10	C-2511	12
Segment, INTERMEDIATE	C-2570	11	C-2556	10	C-2512	12
Hinge Pin w/ Cotter Pin	C-2525	.5	C-2525	.5	C-2525	.7
Handle Pin w/ Washer & Cotter Pin	C-3769	.5	C-3769	.5	C-3769	.5
Retaining Cotter Pin	C-71936	...	C-71936	...	C-71936	...
Safety FLEX Handles Right, Left, Center	C-3765-FH	4	C-3765-FH	4	C-3765-FH	4

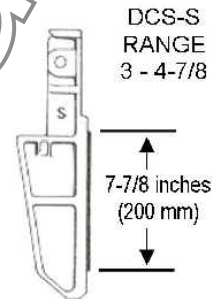

CIRCULAR BUTTONS FOR DCS SLIPS

Slip Set	Drill Collar OD (in.)	P/N	Wt. lbs.	Qty.
DCS-S	3 - 4	2628-49	13	49
	4 - 4-7/8	2620-49	8	49
DCS-R	4-1/2 - 6	2628-63	16	63
	5-1/2 - 7	2620-63	11	63
DCS-L	5-1/2 - 7	2513-88	22	88
	6-3/4 - 8-1/4	2630-88	15	88
	8 - 9-1/2	2630-96	16	96
	8-1/2 - 10	2627-104	26	104
	9-1/4 - 11-1/4	2630-112	19	112
	11 - 12-3/4	2625-136	13	136
	12 - 14	2630-136	16	136

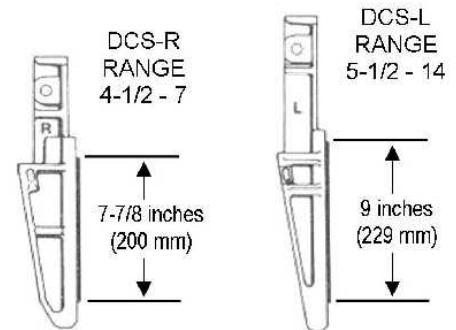

DCS Slip Grip Lengths

Casing Slip



CMS-XL

All Cam-Tech Casing Slips are sold with Cam-Tech Safety Flex Handles, as shown here (ref. page 18)

CMS-XL — EXTRA LONG MULTI-SEGMENT CASING SLIP

Casing OD (in.)	6-5/8	7	7-5/8	8-5/8	9-5/8 ‡	10-3/4 ‡	11-3/4 ‡	13-3/8 ‡
P/N Slip complete with Safety FLEX Handles	C-5315-FH	C-5301-FH	C-5303-FH	C-5305-FH	C-5307-FH	C-5309-FH	C-5311-FH	C-5313-FH
Weight, complete (lbs.)	196	184	181	181	192	209	260	247
Total Segments	12	12	13	13	14	15	17	18
Total Hinge Pins	11	11	12	12	13	14	16	17

‡ This size is furnished with four (4) handles.

Casing OD (in.)	16 ‡	18-5/8 ‡	20 ‡	24 ‡	26 ‡	30 ‡
P/N Slip complete with Safety FLEX Handles	C-5325-FH	C-5333-FH	C-5329-FH	C-5331-FH	C-5346-FH	C-5342-FH
Weight, complete (lbs.)	308	367	383	443	486	546
Total Segments	21	25	26	30	33	37
Total Hinge Pins	20	24	25	29	32	36

‡ This size is furnished with four (4) handles.

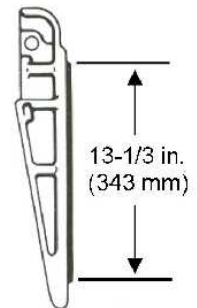

CMS-XL Grip Length

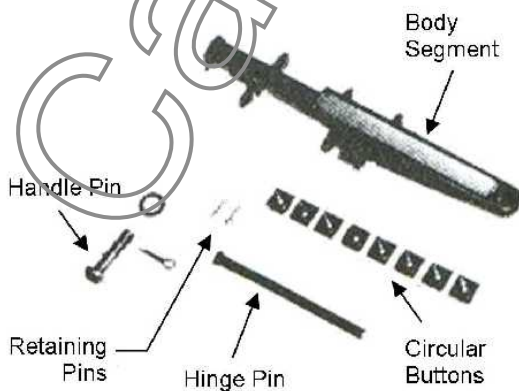

CMS-XL PARTS LIST

Description	Part No.	Wt. lbs.
Segment, RIGHT End	C-5320	12
Segment, LEFT End	C-5321	12
Segment, INTERMEDIATE	C-5322	12
Safety FLEX Handle		
Right, Left, Center	C-3765-FH	4
Hinge Pin with Cotter Pin	C-2525	.6
Handle Pin w/ Washer & Cotter Pin	C-3769	.5
Retaining Screw w/ Lockwasher	C-3748	3.5
Retaining Cotter Pin	C-71936	...

Casing Slip

All Cam-Tech Casing Slips are sold with Cam-Tech Safety Flex Handles, as shown here on CMS-XL (ref. page 18)

CIRCULAR BUTTONS for CMS-XL & CP-S

CMS-XL



Slip Set	Casing OD (in.)	Circular Buttons		
		Part No.	Wt. lbs.	Qty.
CMS-XL	6-5/8	2628-144	36	144
	7	2619-144	36	144
	7-5/8	2630-144	24	144
	8-5/8	2630-156	26	156
	9-5/8	2630-168	28	168
	10-3/4	2630-180	30	180
	11-3/4	2627-204	51	204
	13-3/8	2630-216	36	216
	16	2681-252	43	252
	18-5/8	2626-300	60	300
	20	2631-312	52	312
	24	2631-360	60	360
	26	2631-396	64	396
	30	2631-444	72	444
CP-S	24	2631-156	26	156
	26	2631-168	28	168
	30	2631-192	32	192

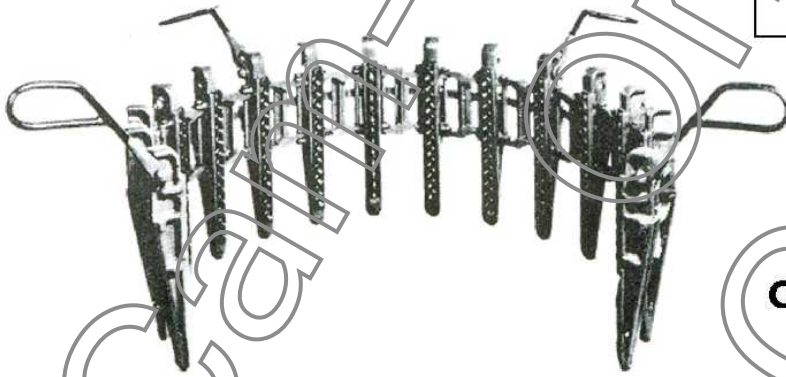

CP-S

CP-S CONDUCTOR PIPE SLIP

Pipe OD (in.)	24	26	30
P/N Slip complete with Safety FLEX Handles	C-5338-FH	C-5344-FH	C-5340-FH
Wt. complete (lbs)	276	296	319
Total Segments	13	14	16
Total Hinge Spacer	12	13	15

All CP-S Slips are furnished with four (4) handles. All parts except Hinge Spacer Block, P/N C-11944, are interchangeable with CMS-XL Slips.

Safety Clamp

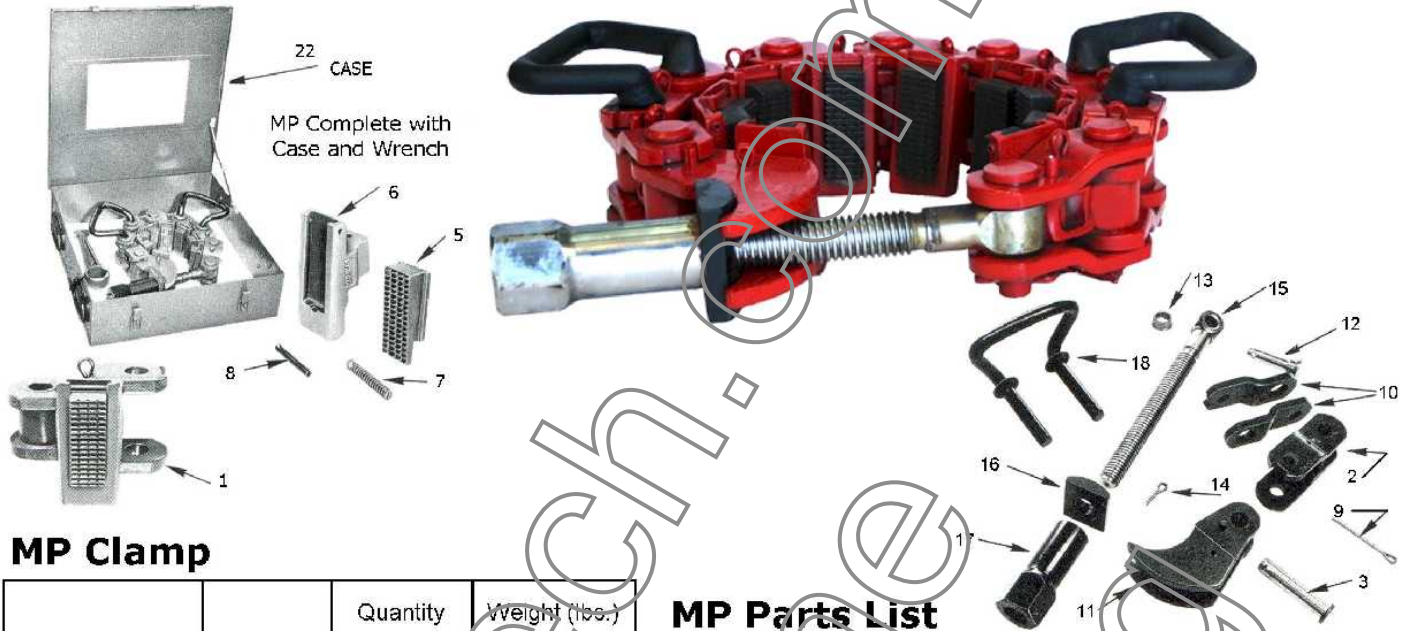

MP Clamp

Range (inches)	Part No.	Quantity		Weight (lbs.)	
		Links	Grip Dies	NO Case	With Case
MP-S					
2-7/8—4-1/8	C-33030	7	8	83	125
4—5	C-33031	8	9	91	133
MP-R					
4-1/2—5-5/8	C-33011	7	8	81	123
5-1/2—7	C-33012	8	9	89	131
6-3/4—8-1/4	C-33013	9	10	97	139
8—9-1/4	C-33014	10	11	105	147
9-1/4—10-1/2	C-33015	11	12	113	155
MP-M					
10-1/2—11-1/2	C-33016	12	13	121	163
11-1/2—12-1/2	C-33017	13	14	129	171
12-1/2—13-5/8	C-33018	14	15	137	179
13-5/8—14-3/4	C-33019	15	16	145	187
14-3/4—15-7/8	C-33020	16	17	153	195
MP-L					
15-7/8—17	C-33021	17	18	173	215
17—18-1/2	C-33022	18	19	181	223
18-1/8—19-3/8	C-33023	19	20	189	231
MP-XL					
19-3/8—20-3/8	C-33024	19	20	196	280
20-3/8—21-1/2	C-33025	20	21	204	288
21—22-5/8	C-33032	21	22	212	296
22-5/8—23-3/4	C-33033	22	23	220	304
23-3/4—24-7/8	C-33034	23	24	228	312
24-7/8—26	C-33035	24	25	236	320
26—27-1/8	C-33036	25	26	244	328
29-3/8—30-1/2	C-33039	28	29	336	354

MP Parts List

Ind. No.	Part No.	Description	Qty
1	C-3319	Link, complete with Pin C-3307	AR
1	C-3335	Link, complete for MP-S only w/Pin C-3307	AR
2	C-3306	Link (w/cotter pin for carrier)	1
3	C-3307	Pin, for link (w/cotter pin)	1
4 ‡	C-3324	Carrier Assy, Die (includes items 5—9)	1
4 ‡	C-3325	Carrier Assy, Die for MP-S only (includes items 5—9)	1
5	C-3310	Die, Grip (w/cotter pin)	1
5	C-3333	Die, Grip (w/cotter pin), MP-S only	1
6	C-3309	Carrier Die	1
7	C-3311	Spring	1
8	C-51604-18	Pin, Roll	1
9	C-51405-80	Pin, Cotter	1
10	C-3318	Bars, Link side, pair	1
11	C-3304	Link, Latch	1
11	C-3321	Link, Latch for MP-XL only	1
12	C-3308	Pin, Screw (w/cotter pin)	1
13	C-3315	Bushing, Screw pin	1
14	C-51405-10	Pin, Cotter (1 per link pin)	AR
15	C-3302	Screw	1
16	C-2714	Washer, thrust	1
17	C-3303	Nut, makeup	1
18	C-3305	Handle (2 required for MP-S, MP-R & MP-M; 4 required for MP-L & MP-XL)	AR
19 ‡	C-3316	Lug, Holddown (2 required for MP-S, MP-R & MP-M; 4 required for MP-L & MP-XL)	Opt
20 ‡	C-3317	Eye, Lifting (2 required for MP-S, MP-R & MP-M; 4 required for MP-L & MP-XL)	1
21 ‡	C-3320	Wrench	1
22 ‡	C-3331	Case	1
22 ‡	C-3334	Case for MP-XL only	1

AR — As Required

Opt — Optional

‡ — Not Shown